

5 QB-F5. QWICKBUILD TIMBER BEARER DETAIL
Scale : 1 : 10

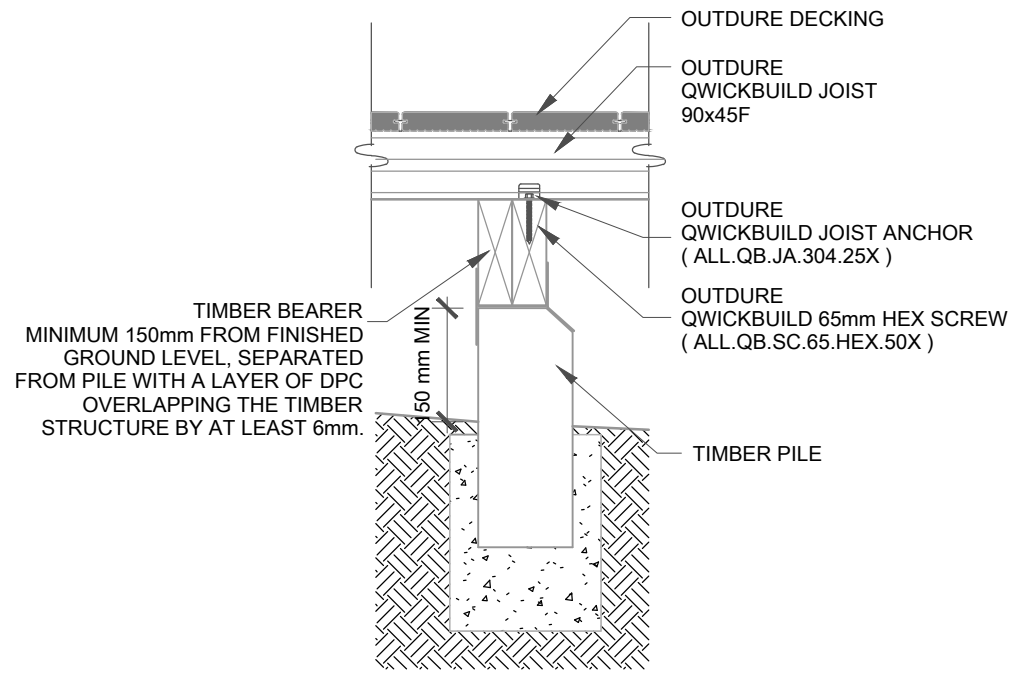

6 QB-F6. QWICKBUILD TIMBER BEARER DETAIL
Scale : 1 : 10

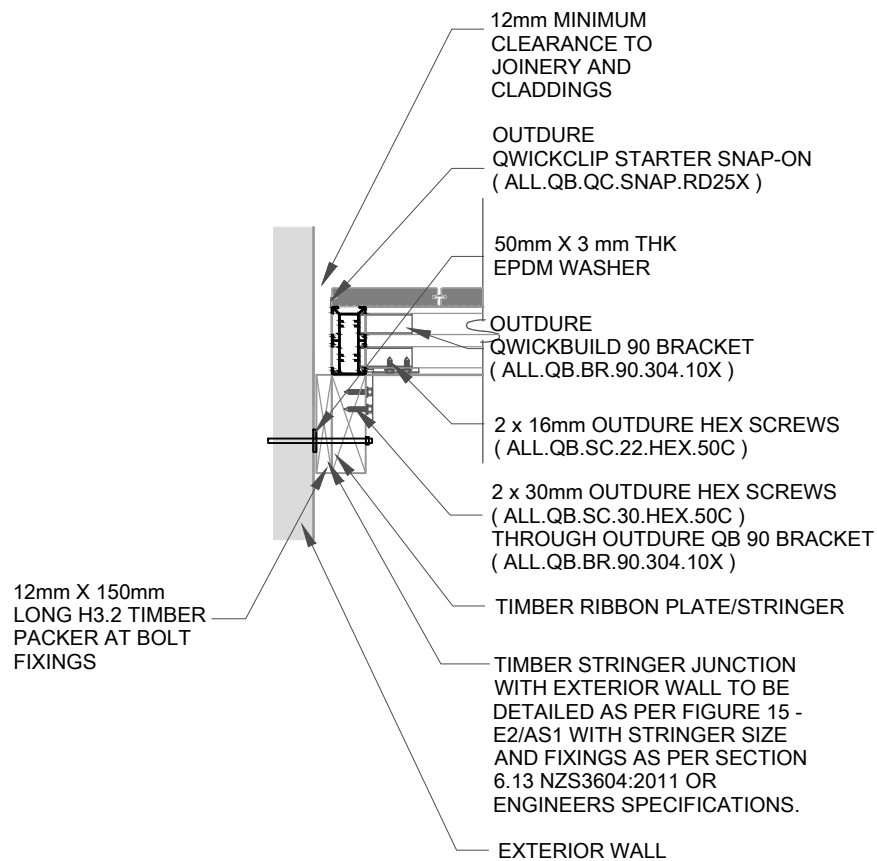

7 QB-F7. QWICKBUILD RIBBON PLATE/STRINGER DETAIL
Scale : 1 : 10

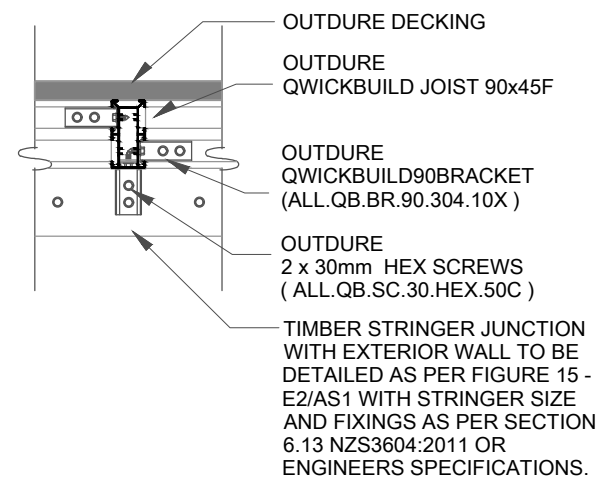

8 QB-F8. QWICKBUILD RIBBON PLATE/STRINGER DETAIL
Scale : 1 : 10

NOTE:
ALL TIMBER PILES AND BEARERS TO BE DESIGNED AND CONSTRUCTED AS PER NZS3604:2011 OR ENGINEERS SPECIFICATION

ALL TIMBER STRUCTURE TO BE SEPARATED FROM ALUMINUM FRAMING WITH A LAYER OF DPC OVERLAPPING THE TIMBER STRUCTURE BY AT LEAST 6mm.

ALL BOLTS IN CONTACT WITH H5 (CCA) TIMBER TO BE STAINLESS STEEL.

TIMBER PILES SHALL COMPLY WITH NZS 3604 AND BE TREATED TO H5 OF NZS 3640. WHERE A TIMBER PILE HAS BEEN CUT AFTER TREATMENT, THE WELL DRIED CUT SURFACE SHALL BE BRUSH-TREATED WITH A LIBERAL APPLICATION OF EITHER CREOSOTE, ZINC NAPHTHENATE, TBTO (BIS-(TRI-N-BUTYL TIN) OXIDE) OR TBTN (BIS-(TRI-N-BUTYL TIN) NAPHTHENATE). THE SURFACE SHALL NOT BE CUT FOR FIXINGS AND OTHER PURPOSES CLOSER THAN 150 mm TO THE FINISHED GROUND LEVEL.